



TPLP SERIES USERS MANUAL

4-20MA LOOP POWERED BURST FIRING MODULE

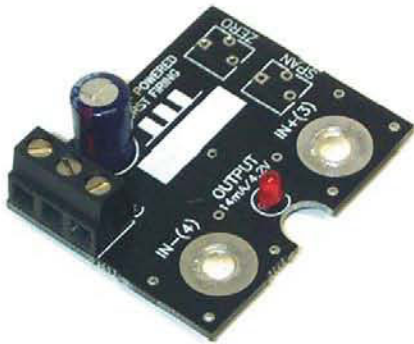

TABLE OF CONTENTS

1.	Ordering Code.....	2
2.	Description.....	2
2.1	Features.....	2
3.	Installation.....	2
3.1	Mounting Instructions.....	3
4.	Operation.....	3
4.1	Command Input.....	3
4.1.1	Input Fail-safe Protection.....	3
4.2	Control Output.....	3
4.2.1	Cycle Time.....	3
4.2.2	Linearity.....	4
4.2.3	Zero and Span Pots.....	4
4.3	Three Phase Operation.....	4
4.4	Wiring of Multiple TPLPs.....	4
5.	Electrical Specifications.....	4
6.	Mechanical Dimensions & Connection Diagram.....	5
7.	Contact Information.....	5
8.	WIRING DIAGRAM.....	5

1. Ordering Code

Part #	Description
TPLP	SSR Mount Power Control Module, Burst Firing Output, 4-20mA Input
TPLPZ	SSR Mount Power Control Module, Burst Firing Output, 4-20mA Input With Zero and Span Pots

2. Description

The TPLP is a power control module designed for use with standard footprint zero cross or random fire SSRs (Solid State Relays). The module mounts directly on the SSR's input screws and derives its power from the 4-20mA command input. The module operates by burst firing the SSR's control input. The power delivered to the load is proportional to the command input signal.

2.1 Features

- Provides precise time proportioned 0-100% output
- Loop powered - no external power supply required
- 4 to 20mA command signal input
- Drops only 6.3 Volts of total loop voltage
- Drives multiple Solid State Relays (SSRs)
- Installs in seconds - mounts on SSR input terminals
- On board LED Indication
- Limited Two Year Warranty

3. Installation



WARNING: FIRE HAZARD!! Even quality electronic components CAN FAIL KEEPING FULL POWER ON! Provide a SEPARATE (redundant) OVER TEMPERATURE SHUTDOWN DEVICE to switch the power off if safe temperatures are exceeded.

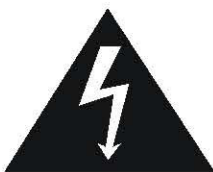

WARNING: HIGH VOLTAGE!! This control is installed on a Solid State Relay with high voltage on it. This control must be installed in a GROUND^{ED} enclosure by a qualified electrician in accordance with applicable local and national codes including NEC and other applicable codes. Provide a safety interlock on the door to remove power before gaining access to the device.

3.1 Mounting Instructions

The TPLP mounts directly to the control input terminals of an SSR. Some relays have short input screws and longer screws will be required to reach through the contacts on the TPLP. Be sure to observe the correct polarity when mounting the module.

4. Operation

4.1 Command Input

The TPLP can accept a 4-20mA input. If more than one TPLP is to be used from the same drive signal, the TPLP inputs should be connected in series. The command input is direct acting, meaning that as the input value increases, the control output increases in direct proportion.

4.1.1 Input Fail-safe Protection

If the signal sent to the TPLP's command input should become electrically open the module's output will be forced to an off state since power will be lost.

4.2 Control Output

The TPLP's SSR output drive is a DC pulsed current limited 4.2V@14mA drive signal. This is more than enough current for driving most 3-32V standard SSRs, however it is still important to review the data sheet for the SSR you would like to use for compatibility with the TPLP's output drive.

4.2.1 Cycle Time

The TPLP has one available cycle time of 350mS (@50%). Custom cycle times are available upon request.

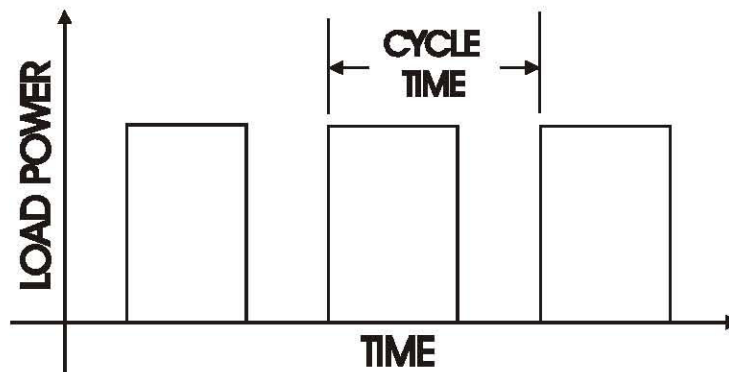

Cycle Time Example

The TPLP is designed to provide the maximum control resolution and response time using a varied output cycle time. While the cycle time is specified at 350mS, this is at 50% power or 12mA input. As 4mA or 20mA is approached, the cycle time increases to limit the minimum on / off times to 100mS. This advanced approach maximizes the control resolution when the module is used with a zero cross fired SSR.

The cycle times change with the command input as follows:

Command	5mA	6mA	8mA	12mA	16mA	18mA	19mA
Cycle Time	1.3s	0.7s	0.4s	0.35s	0.4s	0.7s	1.3s

4.2.2 Linearity

The control output linearity is +/- 2% for the version without the zero and span potentiometers. Much tighter linearity can be achieved by adjusting the zero and span pots to optimize the linearity over the control range of the process.

4.2.3 Zero and Span Pots

The TPLP can be ordered with Zero and Span pots as the TPLPZ. This version allows the user to calibrate the low and high ends of the control range for the best possible linearity over the control range. It will also allow use of the module in load balancing applications and to skew the output response to meet specific needs.

4.3 Three Phase Operation

One TPLP can be used to control two poles of a three phase load using two SSRs with their control inputs wired in parallel. The Module should be wired as shown in the wiring diagram, but with separate load circuits for each leg. Make sure that the total input current requirements of the two SSRs can be achieved with the TPLP.

4.4 Wiring of Multiple TPLPs

If more than one TPLP is to be used from a single command signal, the command inputs should be wired in series, not in parallel.

5. Electrical Specifications

- Command Input** - 4 to 20mA.
- Control Output** - 4.2V/14mA. Short Circuit Protected.
- Control output is direct acting.
- Cycle Time** - 350mS at 50% output.
- Cycle time greater at ends for optimal output resolution.
- Output Linearity** - +/- 2% of Full Scale. (+/- 1% with zero and span pots)
- Zero Pot Adjustment** - +/- 2% of full scale.
- Span Pot Adjustment** - +/- 8% of full scale.

6. Mechanical Dimensions & Connection Diagram

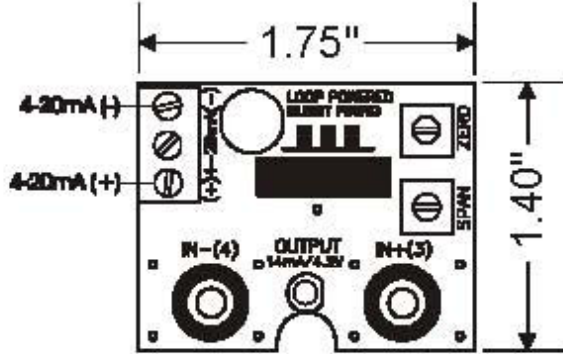

Max Height is 0.6"

8. WIRING DIAGRAM

